

≡ 'B' 8C I 6H5 G?

'B: CFA' 8F5K 'B; 'C:: 7 9'C: '9FFC FG'

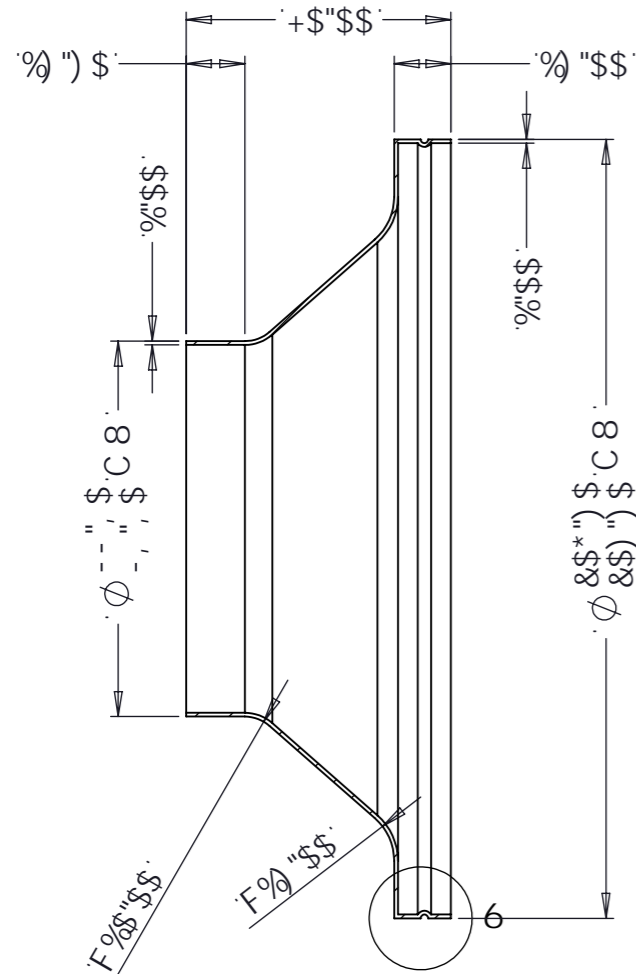

G97 HC B 5!5
G7 5 @9% . &

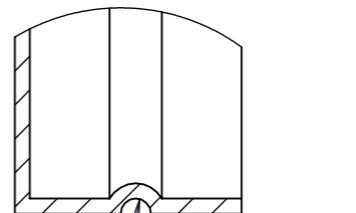

89H @6
G7 5 @& . %

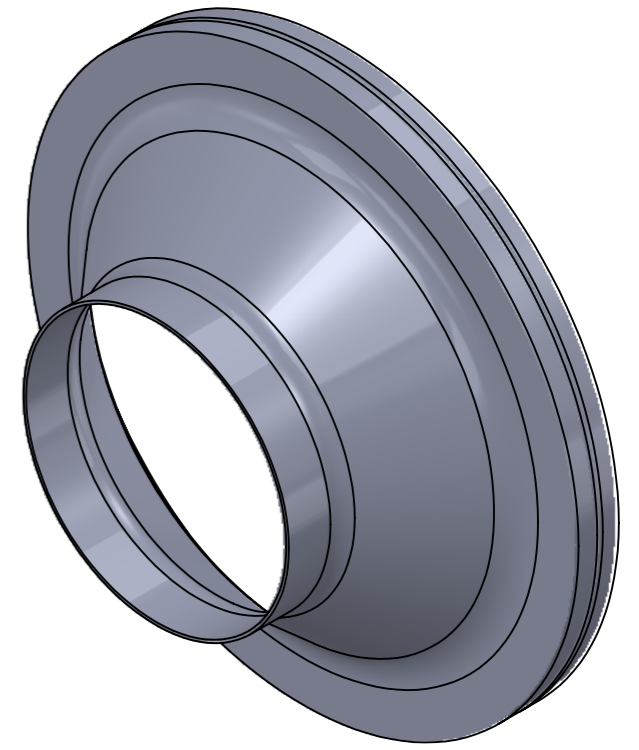
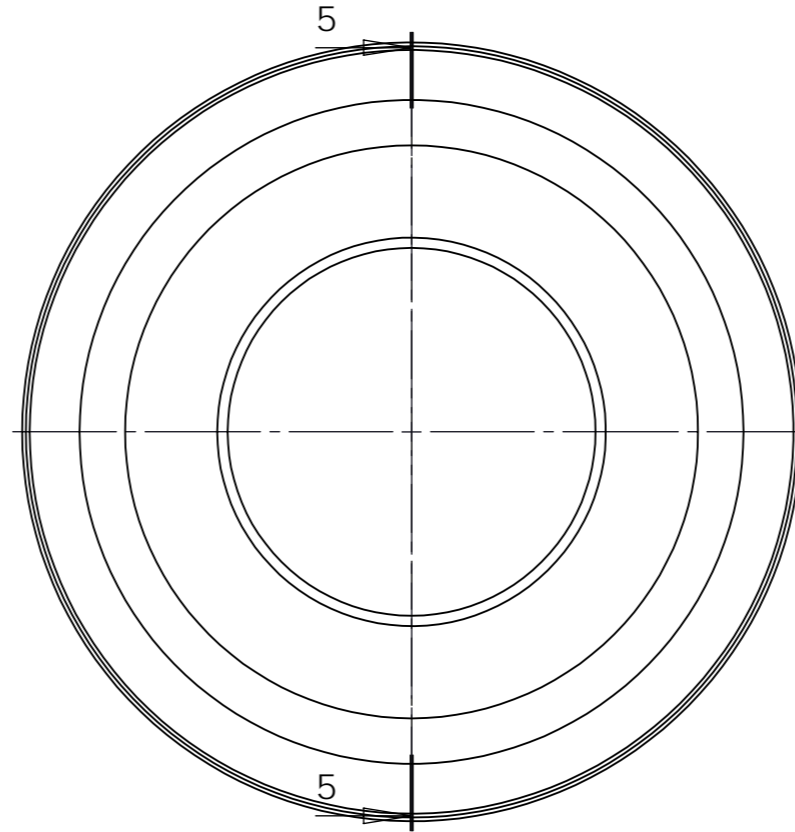

Dfc Xi Whjcb. Gja cb : UffYb

7 cgh]b[. Gja cb : UffYb

5' G<99H% C : %

GG 9'	8 9G7 F-DHC B'	B #H5 @G	97 B-Bc	85HP	5 @8-A 9BG€ BG-B'A @A 9HFG'	F9A CJ 95 @6l FFG 5B8 G-5FD98: 9G 1 B @GGC H-9FK -69 G5H98	FYj YfjY @a jYX l b]h&7 \UbX YfgFck 7 c WYgYf 9ggYl 7C %&<; \$%&\$* , ****' k k k "fYj YfjY "hX"i _	8F5K B	5DD	D5FHBT A 69F	F \$%G9* &&'	
%	C F ≠ B5 @GG 9	6A	\$%#%&#&\$%		HC @9F5B7 9Gf5H&\$7 l 1 B @GGC H-9FK -69 G5H98	<C @9HC 6Q) \$\$ % .) * H:F958GHC 6G *(% % % A 9H7 7C1FG9' 6GDH:F958GHC 6G&+ A 98: H		6A	85HP	H#29	&\$*!\$Sa a '<[\ : 'ck :]HYf5XUdhYf	
					BCA B5 @B95F 8-A 9BGC BG			5bcX]hYX '6UW_			A 5HF5@ 5`cm	
					CJ 9F1-B7 @ OS\$\$ \$''\$	G F: 579 : B G<9G A @B: B, H FB-B: B+ : F-B8B: B*		G7 5 @			BGD97 HC B @J 9@	D5FHET 5@#M: F589
					SI&\$S Z# 'S') \$ Z# 'S') %			8c BchGWY '8fuk]b[BF: "BC"	F \$%G9* &&' !H
					8) SI%\$\$ Z# %\$\$ Z# 'S'8\$			A 5GG				
					%\$\$S D@ G Z# &\$\$ Z# 'S" \$	5B: 8-A G Z# 'S') fi	H: G5 8F5K B: 'G5 DF J5H95B8 7CB: 898H5@ 7CA A1 B-75HC B'					